



Dell™ Dimension™ 8400 Service Manual

[Before You Begin](#)
[Opening the Computer Cover](#)
[Technical Overview](#)
[Specifications](#)
[Advanced Troubleshooting](#)
[System Setup](#)
[Removing and Installing Parts](#)
[Closing the Computer Cover](#)

Notes, Notices, and Cautions

-  **NOTE:** A NOTE indicates important information that helps you make better use of your computer.
-  **NOTICE:** A NOTICE indicates either potential damage to hardware or loss of data and tells you how to avoid the problem.
-  **CAUTION:** A CAUTION indicates a potential for property damage, personal injury, or death.

Abbreviations and Acronyms

For a complete list of abbreviations and acronyms, see the *Dell Dimension Owner's Manual*.

If you purchased a Dell™ n Series computer, any references in this document to Microsoft® Windows® operating systems are not applicable.

-  **NOTE:** Some features or services may not be available for your computer or in certain countries.

Information in this document is subject to change without notice.
© 2004 Dell Inc. All rights reserved.

Reproduction in any manner whatsoever without the written permission of Dell Inc. is strictly forbidden.

Trademarks used in this text: *Dell*, the *DELL* logo, and *Dimension* are trademarks of Dell Inc.; *Intel* and *Pentium* are registered trademarks of Intel Corporation; *Microsoft* and *Windows* are registered trademarks of Microsoft Corporation.

Other trademarks and trade names may be used in this document to refer to either the entities claiming the marks and names or their products. Dell Inc. disclaims any proprietary interest in trademarks and trade names other than its own.

Model DHM

November 2004 Rev. A00

Advanced Troubleshooting

Dell™ Dimension™ 8400 Service Manual

- [Power Lights](#)
- [Diagnostic Lights](#)
- [Beep Codes](#)
- [System Messages](#)

Power Lights

⚠ CAUTION: Before you begin any of the procedures in this section, follow the safety instructions in the *Product Information Guide*.

The power button light located on the front of the computer illuminates and blinks or remains solid to indicate different states:

- 1 If the power light is green and the computer is not responding, see "[Diagnostic Lights](#)."
- 1 If the power light is blinking green, the computer is in standby mode. Press a key on the keyboard, move the mouse, or press the power button to resume normal operation.
- 1 If the power light is off, the computer is either turned off or is not receiving power.
 - o Reseat the power cable into both the power connector on the back of the computer and the electrical outlet.
 - o If the computer is plugged into a power strip, ensure that the power strip is plugged into an electrical outlet and that the power strip is turned on. Also bypass power protection devices, power strips, and power extension cables to verify that the computer turns on properly.
 - o Ensure that the electrical outlet is working by testing it with another device, such as a lamp.
 - o Ensure that the main power cable and front panel cable are securely connected to the [system board](#).
- 1 If the power light is blinking, the computer is receiving electrical power, but an internal power problem might exist.
 - o Ensure that the voltage selection switch is set to match the AC power at your location (if applicable).
 - o Ensure that the processor power cable is securely connected to the [system board](#).
- 1 If the power light is steady amber, a device might be malfunctioning or incorrectly installed.
 - o Remove and then reinstall the [memory modules](#).
 - o Remove and then reinstall any [cards](#).
 - o Remove and then reinstall the [graphics card](#), if applicable.
- 1 Eliminate interference. Some possible causes of interference are:
 - o Power, keyboard, and mouse extension cables
 - o Too many devices on a power strip
 - o Multiple power strips connected to the same electrical outlet

Diagnostic Lights

⚠ CAUTION: Before you begin any of the procedures in this section, follow the safety instructions located in the *Product Information Guide*.

To help you troubleshoot a problem, your computer has four lights labeled "A," "B," "C," and "D" on the back panel. The lights can be yellow or green. When the computer starts normally, the lights flash. After the computer starts, all four lights display solid green. If the computer malfunctions, the color and sequence of the lights identify the problem.

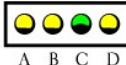
Light Pattern	Problem Description	Suggested Resolution
 A B C D	The computer is in a normal off condition or a possible pre-BIOS failure has occurred.	Plug the computer into a working electrical outlet and press the power button.
 A B C D	A possible processor failure has occurred.	Contact Dell.

	Memory modules are detected, but a memory failure has occurred.	<ol style="list-style-type: none"> 1 If you have two or more memory modules installed, remove the modules, reinstall one module, and then restart the computer. If the computer starts normally, reinstall an additional module. Continue until you have identified a faulty module or reinstalled all modules without error. 1 If available, install properly working memory of the same type into your computer. 1 If the problem persists, contact Dell.
	A possible graphics card failure has occurred.	<ol style="list-style-type: none"> 1 If the computer has a graphics card, remove the card, reinstall it (see "PCI Express Cards"), and then restart the computer. 1 If the problem still exists, install a graphics card that you know works and restart the computer. 1 If the problem persists or the computer has integrated graphics, contact Dell.
	A possible floppy or hard drive failure has occurred.	Reseat all power and data cables and restart the computer.
	A possible USB failure has occurred.	Reinstall all USB devices, check cable connections, and then restart the computer.
	No memory modules are detected.	<ol style="list-style-type: none"> 1 If you have two or more memory modules installed, remove the modules, reinstall one module, and then restart the computer. If the computer starts normally, reinstall an additional module. Continue until you have identified a faulty module or reinstalled all modules without error. 1 If available, install properly working memory of the same type into your computer. 1 If the problem persists, contact Dell.
	Memory modules are detected, but a memory configuration or compatibility error exists.	<ol style="list-style-type: none"> 1 Ensure that no special memory module/memory connector placement requirements exist (see "Memory"). 1 Verify that the memory modules that you are installing are compatible with your computer (see "Memory"). 1 If the problem persists, contact Dell.
	A possible expansion card failure has occurred.	<ol style="list-style-type: none"> 1. Determine if a conflict exists by removing a card (not a graphics card) (see "Cards") and restarting the computer. 2. If the problem persists, reinstall the card that you removed, remove a different card, and then restart the computer. 3. Repeat this process for each card. If the computer starts normally, troubleshoot the last card removed from the computer for resource conflicts. 4. If the problem persists, contact Dell.
	Another failure has occurred.	<ol style="list-style-type: none"> 1 Ensure that the cables are properly connected to the system board from the hard drive, CD drive, and DVD drive. 1 If there is an error message on your screen identifying a problem with a device (such as the floppy drive or hard drive), check the device to make sure it is functioning properly. 1 The operating system is attempting to boot from a device (such as the floppy drive or hard drive); check system setup (see "Boot Sequence") to make sure the boot sequence is correct for the devices installed on your computer. 1 If the problem persists, contact Dell.
	The computer is in a normal operating condition after POST.	None.
<p> = yellow = green = off </p>		

Beep Codes

Your computer might emit a series of beeps during start-up if the monitor cannot display errors or problems. This series of beeps, called a beep code, identifies a problem. One possible beep code (code 1-3-1) consists of one beep, a burst of three beeps, and then one beep. This beep code tells you that the computer encountered a memory problem.

[Reseating the memory modules](#) may fix the beep code errors in the following table. If the problem persists, see "Contacting Dell" in your *Owner's Manual* for instructions on obtaining technical assistance.

Code	Cause
1-3-1 through 2-4-4	Memory not being properly identified or used
4-3-1	Memory failure above address 0FFFFh

If you hear one of the following beep codes, see "Contacting Dell" in your *Owner's Manual* for instructions on obtaining technical assistance.

Code	Cause
1-1-2	Microprocessor register failure
1-1-3	NVRAM
1-1-4	ROM BIOS checksum failure
1-2-1	Programmable interval timer
1-2-2	DMA initialization failure
1-2-3	DMA page register read/write failure
3-1-1	Slave DMA register failure
3-1-2	Master DMA register failure
3-1-3	Master interrupt mask register failure
3-1-4	Slave interrupt mask register failure
3-2-2	Interrupt vector loading failure
3-2-4	Keyboard Controller Test failure
3-3-1	NVRAM power loss
3-3-2	NVRAM configuration
3-3-4	Video Memory Test failure
3-4-1	Screen initialization failure
3-4-2	Screen retrace failure
3-4-3	Search for video ROM failure
4-2-1	No time tick
4-2-2	Shutdown failure
4-2-3	Gate A20 failure
4-2-4	Unexpected interrupt in protected mode
4-3-3	Timer-chip counter 2 failure
4-3-4	Time-of-day clock stopped
4-4-1	Serial or parallel port test failure
4-4-4	Cache test failure

System Messages

 **NOTE:** If the message you received is not listed in the table, see the documentation for either the operating system or the program that was running when the message appeared.

Message	Possible Cause	Corrective Action
8042 Gate-A20 error	The keyboard controller failed its test.	If you receive this message after you make changes in the system setup program, enter the system setup program and restore the original value(s).
Address Line Short!	An error in the address decoding circuitry in the memory has occurred.	Reseat the memory modules .
C: Drive Error C: Drive Failure	The hard drive is not working or is not configured correctly.	Ensure that the drive is installed correctly in the computer and defined correctly in the system setup program.
Cache Memory Bad, Do Not Enable Cache	The cache memory is not operating.	See "Contacting Dell" in your <i>Owner's Manual</i> for instructions on obtaining technical assistance.
CH-2 Timer Error	An error is occurring on the timer on the system board.	See "Contacting Dell" in your <i>Owner's Manual</i> for instructions on obtaining technical assistance.
CMOS Battery State Low CMOS Checksum Failure CMOS System Options Not Set CMOS Display Type Mismatch CMOS Memory Size Mismatch	The system configuration information in the system setup program is incorrect or the battery charge may be low.	Enter the system setup program, verify the system configuration, and then restart the computer.

CMOS Time and Date Not Set		
Diskette Boot Failure	Drive A or B is present but has failed the BIOS POST.	Ensure that the drive is installed correctly in the computer and defined correctly in the system setup program. Check the interface cable at both ends.
DMA Error DMA 1 Error DMA 2 Error	Error in the DMA controller on the system board.	The keyboard or system board may need to be replaced.
FDD Controller Failure HDD Controller Failure	The BIOS cannot communicate with the floppy drive or hard drive controller.	Ensure that the floppy drive or the hard drive is installed correctly in the computer and defined correctly in the system setup program. Check the interface cable at both ends.
INTR1 Error INTR2 Error	An interrupt channel on the system board failed to POST.	The keyboard or system board may need to be replaced.
Invalid Boot Diskette	The operating system cannot be located on drive A or drive C.	Enter the system setup program and confirm that drive A or drive C is properly identified.
Keyboard Error	The BIOS has detected a stuck key.	Ensure that nothing is resting on the keyboard; if a key appears to be stuck, carefully pry it up. If the problem persists, you may need to replace the keyboard.
KB/Interface Error	An error occurred with the keyboard connector.	Ensure that nothing is resting on the keyboard; if a key appears to be stuck, carefully pry it up. If the problem persists, you may need to replace the keyboard.
No ROM Basic	The operating system cannot be located on drive A or drive C.	Enter the system setup program and confirm that drive A or drive C is properly identified.

[Back to Contents Page](#)

Before You Begin

Dell™ Dimension™ 8400 Service Manual

- [Getting Started](#)
 - [Recommended Tools](#)
 - [Turning Off Your Computer](#)
 - [Before Working Inside Your Computer](#)
-

Getting Started

This section provides procedures for removing and installing the components in your computer. Unless otherwise noted, each procedure assumes that the following conditions exist:

1. You have performed the steps in "[Turning Off Your Computer](#)" and "[Before Working Inside Your Computer](#)."
 1. You have read the safety information in your Dell™ *Product Information Guide*.
 1. A component can be replaced by performing the removal procedure in reverse order.
-

Recommended Tools

The procedures in this document may require the following tools:

1. Small flat-blade screwdriver
 1. Phillips screwdriver
 1. Flash BIOS update program floppy or CD
-

Turning Off Your Computer

➡ **NOTICE:** To avoid losing data, save and close any open files and exit any open programs before you turn off your computer.

1. Shut down the operating system:
 - a. Save and close any open files, exit any open programs, click the **Start** button, and then click **Turn Off Computer**.
 - b. In the **Turn off computer** window, click **Turn off**.

The computer turns off after the operating system shutdown process finishes.

2. Ensure that the computer and any attached devices are turned off. If your computer and attached devices did not automatically turn off when you shut down your operating system, press and hold the power button for 4 seconds.
-

Before Working Inside Your Computer

Use the following safety guidelines to help protect your computer from potential damage and to help ensure your own personal safety.

⚠ **CAUTION:** Before you begin any of the procedures in this section, follow the safety instructions located in the *Product Information Guide*.

⚠ **CAUTION:** Handle components and cards with care. Do not touch the components or contacts on a card. Hold a card by its edges or by its metal mounting bracket. Hold a component such as a processor by its edges, not by its pins.

➡ **NOTICE:** Only a certified service technician should perform repairs on your computer. Damage due to servicing that is not authorized by Dell is not covered by your warranty.

➡ **NOTICE:** When you disconnect a cable, pull on its connector or on its strain-relief loop, not on the cable itself. Some cables have a connector with locking tabs; if you are disconnecting this type of cable, press in on the locking tabs before you disconnect the cable. As you pull connectors apart, keep them evenly aligned to avoid bending any connector pins. Also, before you connect a cable, ensure that both connectors are correctly oriented and aligned.

➡ **NOTICE:** To avoid damaging the computer, perform the following steps before you begin working inside the computer.

1. [Turn off your computer](#).

 **NOTICE:** To disconnect a network cable, first unplug the cable from your computer and then unplug it from the network device.

2. Disconnect any telephone or telecommunication lines from the computer.
3. Disconnect your computer and all attached devices from their electrical outlets, and then press the power button to ground the system board.

 **CAUTION:** To guard against electrical shock, always unplug your computer from the electrical outlet before opening the cover.

4. [Open the computer cover.](#)

 **NOTICE:** Before touching anything inside your computer, ground yourself by touching an unpainted metal surface, such as the metal at the back of the computer. While you work, periodically touch an unpainted metal surface to dissipate any static electricity that could harm internal components.

[Back to Contents Page](#)

Opening the Computer Cover

Dell™ Dimension™ 8400 Service Manual

⚠ CAUTION: Before you begin any of the procedures in this section, follow the safety instructions located in the *Product Information Guide*.

⚠ CAUTION: To guard against electrical shock, always unplug your computer from the electrical outlet before opening the cover.

1. Follow the procedures in "[Before You Begin](#)."

👉 NOTICE: Ensure that sufficient space exists to support the open cover—at least 30 cm (1 ft) of desk top space.

2. Lay the computer on its side so that the arrow on the bottom of the computer points up.

3. Open the cover:

- a. Facing the back of the computer, press the release button on the right side of the computer with one hand while pulling up on the top of the cover with the other hand.
- b. Press the release button on the left side of the computer with one hand while pulling up on the top of the cover with the other hand.
- c. Hold the bottom of the computer with one hand, and then pull open the cover with the other hand.

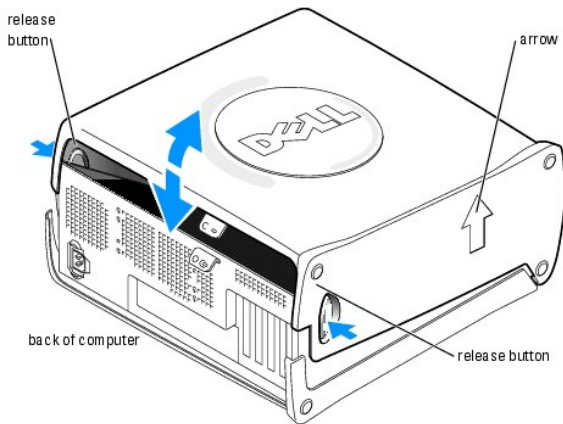

[Back to Contents Page](#)

Closing the Computer Cover

Dell™ Dimension™ 8400 Service Manual

 **CAUTION:** Before you begin any of the procedures in this section, follow the safety instructions located in the *Product Information Guide*.

1. Ensure that all cables are connected, and fold cables out of the way.
Gently pull the power cables toward you so that they do not get caught underneath the drives.
2. Ensure that no tools or extra parts are left inside the computer.
3. Close the cover:
 - a. Pivot the cover down.
 - b. Press down on the right side of the cover until it closes.
 - c. Press down on the left side of the cover until it closes.
 - d. Ensure that both sides of the cover are locked. If not, repeat all of [step 3](#).

 **NOTICE:** To connect a network cable, first plug the cable into the network device and then plug it into the computer.

4. Connect your computer and devices to electrical outlets, and turn them on.

[Back to Contents Page](#)

Removing and Installing Parts

Dell™ Dimension™ 8400 Service Manual

- [Memory](#)
 - [Cards](#)
 - [Drives](#)
 - [Hard Drive](#)
 - [Front-Panel Inserts](#)
 - [Floppy Drive](#)
 - [CD/DVD Drive](#)
 - [Airflow Shroud](#)
 - [Processor](#)
 - [System Board](#)
 - [Power Supply](#)
 - [Battery](#)
-

Memory

You can increase your computer memory by installing memory modules on the system board.

Your computer supports DDR2 memory. For additional information on the type of memory supported by your computer, see "[Memory](#)".

DDR2 Memory Overview

DDR2 memory modules should be installed in *pairs of matched memory size, speed, and technology*. If the DDR2 memory modules are not installed in matched pairs, the computer will continue to operate, but with a slight reduction in performance. See the label on the upper-right corner of the module to determine the module's capacity.



 **NOTE:** Always install DDR2 memory modules in the order indicated on the system board.

The recommended memory configurations are:

- A pair of matched memory modules installed in DIMM connectors 1 and 2
- or
- A pair of matched memory modules installed in DIMM connectors 1 and 2 and another matched pair installed in DIMM connectors 3 and 4

 **NOTICE:** Do not install ECC memory modules.

- 1 If you install mixed pairs of DDR2 400-MHz (PC2-3200) and DDR2 533-MHz (PC2-4200) memory, the modules function at the slowest speed installed. Similarly, if you install memory modules with mixed CAS Latency (CL) rates, the modules function at the speed and CAS latency capabilities of the slowest DIMM.
- 1 Be sure to install a single memory module in DIMM connector 1, the connector closest to the processor, before you install modules in the other connectors.

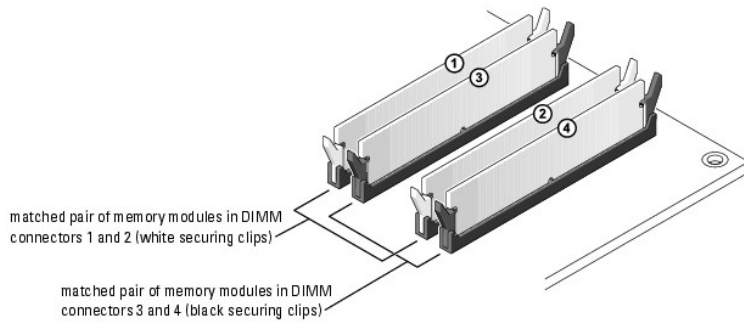

NOTE: Memory purchased from Dell is covered under your computer warranty.

NOTICE: If you remove your original memory modules from the computer during a memory upgrade, keep them separate from any new modules that you may have, even if you purchased the new modules from Dell. If possible, *do not* pair an original memory module with a new memory module. Otherwise, your computer may not start properly. You should install your original memory modules in pairs either in DIMM connectors 1 and 2 or DIMM connectors 3 and 4.

Addressing Memory With 4-GB Configurations

Your computer supports a maximum of 4 GB of memory when you use four 1-GB DIMMs. Current operating systems, such as Microsoft® Windows® XP, can only use a maximum of 4 GB of address space; however, the amount of memory available to the operating system is less than 4 GB. Certain components within the computer require address space in the 4-GB range. Any address space reserved for these components cannot be used by computer memory.

Installing Memory

CAUTION: Before you begin any of the procedures in this section, follow the safety instructions located in the *Product Information Guide*.

NOTICE: To prevent static damage to components inside your computer, discharge static electricity from your body before you touch any of your computer's electronic components. You can do so by touching an unpainted metal surface on the computer chassis.

1. Follow the procedures in "[Before You Begin](#)."
2. Lay the computer on its side so that the system board is on the bottom of the inside of the computer.
3. Press out the securing clip at each end of the memory module connector.

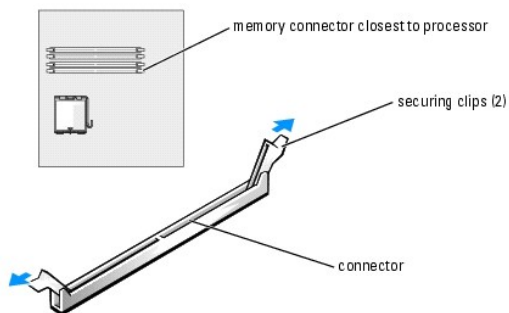

4. Align the notch on the bottom of the module with the crossbar in the connector.

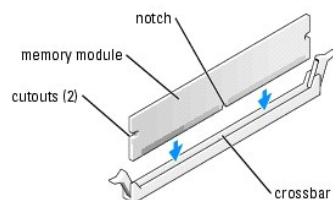

➡ **NOTICE:** To avoid damage to the memory module, press the module straight down into the connector while you apply equal force to each end of the module.

5. Insert the module into the connector until the module snaps into position.

If you insert the module correctly, the securing clips snap into the cutouts at each end of the module.

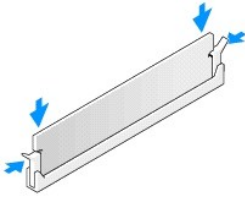

6. [Close the computer cover.](#)

➡ **NOTICE:** To connect a network cable, first plug the cable into the network device and then plug it into the computer.

7. Connect your computer and devices to electrical outlets, and turn them on.
8. Right-click the **My Computer** icon and click **Properties**.
9. Click the **General** tab.
10. To verify that the memory is installed correctly, check the amount of memory (RAM) listed.

Removing Memory

⚠ **CAUTION:** Before you begin any of the procedures in this section, follow the safety instructions located in the *Product Information Guide*.

➡ **NOTICE:** To prevent static damage to components inside your computer, discharge static electricity from your body before you touch any of your computer's electronic components. You can do so by touching an unpainted metal surface on the computer chassis.

1. Follow the procedures in "[Before You Begin](#)."
2. Press out the securing clip at each end of the memory module connector.
3. Grasp the module and pull up.

If the module is difficult to remove, gently ease the module back and forth to remove it from the connector.

Cards

⚠ **CAUTION:** Before you begin any of the procedures in this section, follow the safety instructions located in the *Product Information Guide*.

➡ **NOTICE:** To prevent static damage to components inside your computer, discharge static electricity from your body before you touch any of your computer's electronic components. You can do so by touching an unpainted metal surface on the computer chassis.

Your Dell™ computer provides the following slots for PCI and PCI Express cards:

- 1 Three PCI card slots
- 1 One PCI Express x16 card slot
- 1 One PCI Express x1 card slot

PCI Cards



If you are installing or replacing a card, follow the procedures in the next section. If you are removing but not replacing a PCI card, see "[Removing a PCI Card.](#)"

If you are replacing a card, remove the current driver for the card from the operating system.

If you are installing or replacing a PCI Express card, see "[Installing a PCI Express Card.](#)"

Installing a PCI Card

1. Follow the procedures in "[Before You Begin.](#)"
2. Press the lever on the card retention arm and raise the retention arm.

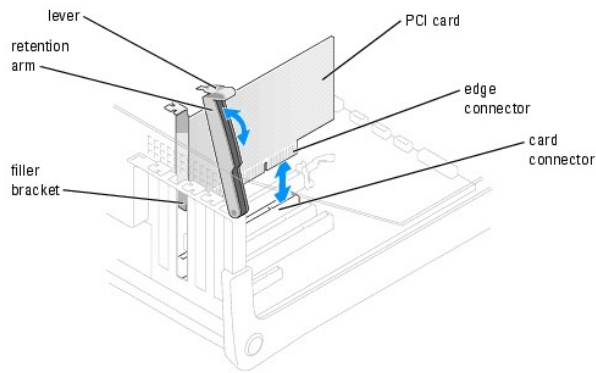

3. If you are installing a new card, remove the filler bracket to create a card-slot opening. Then continue with [step 5.](#)

4. If you are replacing a card that is already installed in the computer, remove the card.

If necessary, disconnect any cables connected to the card. Grasp the card by its top corners, and ease it out of its connector.

5. Prepare the card for installation.

See the documentation that came with the card for information on configuring the card, making internal connections, or otherwise customizing it for your computer.

⚠ CAUTION: Some network adapters automatically start the computer when they are connected to a network. To guard against electrical shock, be sure to unplug your computer from its electrical outlet before installing any cards.

6. Place the card in the connector and press down firmly. Ensure that the card is fully seated in the slot.

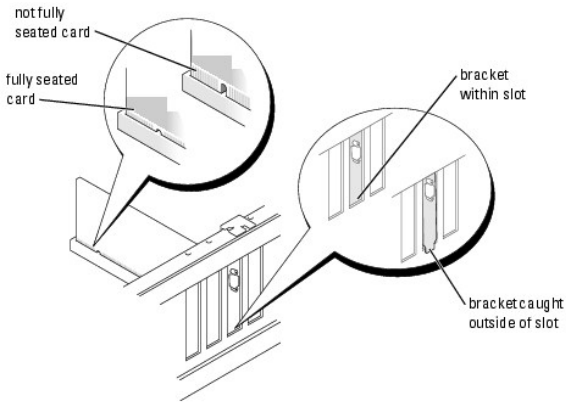

7. Before you lower the retention arm, ensure that:
 - 1 The tops of all cards and filler brackets are flush with the alignment bar.
 - 1 The notch in the top of the card or filler bracket fits around the alignment guide.
8. Press the retention arm into place, securing the card(s) in the computer.

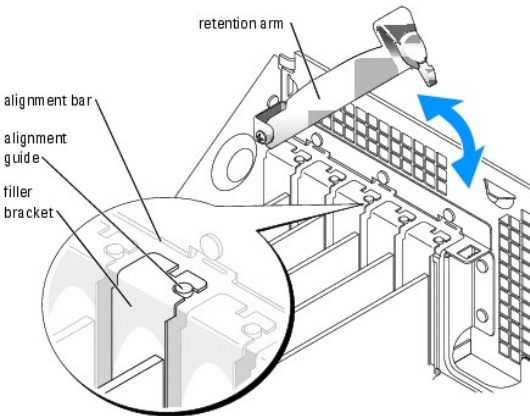

➡ **NOTICE:** Do not route card cables over or behind the cards. Cables routed over the cards can prevent the computer cover from closing properly or cause damage to the equipment.

9. Connect any cables that should be attached to the card.
See the documentation for the card for information about the card's cable connections.

➡ **NOTICE:** To connect a network cable, first plug the cable into the network device and then plug it into the computer.

10. [Close the computer cover](#), reconnect the computer and devices to electrical outlets, and then turn them on.

11. If you installed a sound card:
 - a. [Enter system setup](#), select **Audio Controller**, and then change the setting to **Off**.
 - b. Connect external audio devices to the sound card's connectors. Do not connect external audio devices to the microphone, speaker/headphone, or line-in connectors on the back panel.
12. If you installed an add-in network adapter and want to disable the integrated network adapter:
 - a. [Enter system setup](#), select **Network Controller**, and then change the setting to **Off**.
 - b. Connect the network cable to the add-in network adapter's connectors. Do not connect the network cable to the integrated connector on the back panel.
13. Install any drivers required for the card as described in the card documentation.

Removing a PCI Card

1. Follow the procedures in "[Before You Begin](#)."
2. Press the lever on the card retention arm and raise the retention arm.
3. If necessary, disconnect any cables connected to the card.
4. Grasp the card by its top corners, and ease it out of its connector.
5. If you are removing the card permanently, install a filler bracket in the empty card-slot opening.

If you need a filler bracket, contact Dell.

 **NOTE:** Installing filler brackets over empty card-slot openings is necessary to maintain FCC certification of the computer. The brackets also keep dust and dirt out of your computer.

6. Lower the retention arm and press it into place, securing the card(s) in the computer.

 **NOTICE:** To connect a network cable, first plug the cable into the network device and then plug it into the computer.

7. [Close the computer cover](#), reconnect the computer and devices to electrical outlets, and then turn them on.

8. Remove the card's driver from the operating system.

9. If you removed a sound card:

- a. [Enter system setup](#), select **Audio Controller**, and then change the setting to **On**.
- b. Connect external audio devices to the audio connectors on the back panel of the computer.

10. If you removed an add-in network connector:

- a. [Enter system setup](#), select **Network Controller**, and then change the setting to **On**.
- b. Connect the network cable to the integrated connector on the back panel of the computer.

PCI Express Cards

Your computer supports one PCI Express x16 card and one PCI Express x1 card.

 **NOTICE:** PCI Express graphics cards that run higher than 75 W may require an additional cooling fan. Otherwise, your card could overheat and damage your computer.

If a card fan is not present in your computer and you are installing a graphics card that runs at 75 W or higher, contact Dell to find out how to purchase a card fan.

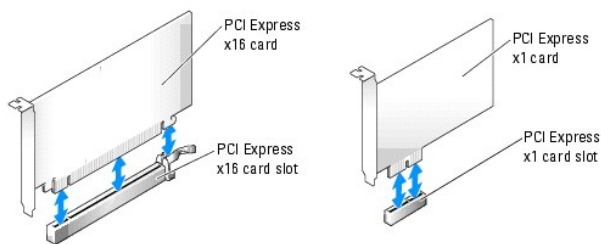

If you are installing or replacing a PCI Express card, follow the procedures in the next section. If you are removing but not replacing a card, see "[Removing a PCI Express Card](#)."

If you are replacing a card, remove the current driver for the card from the operating system.

If you are installing or replacing a PCI card, see "[Installing a PCI Card](#)."

Installing a PCI Express Card

1. Follow the procedures in "[Before You Begin](#)."

2. Press the lever on the card retention arm and raise the retention arm.

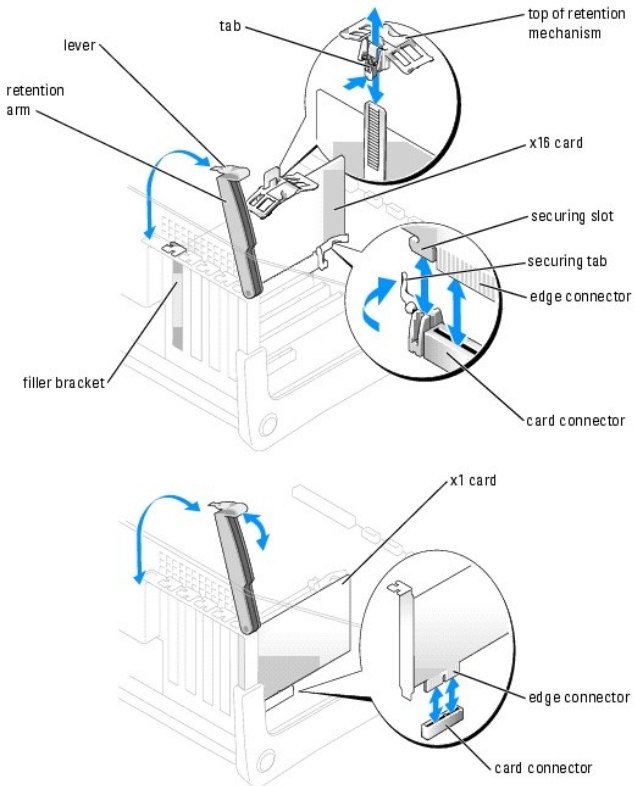

3. If you are installing a new card, remove the filler bracket to create a card-slot opening. Then continue with [step 5](#).

4. If you are replacing a card that is already installed in the computer, remove the card.

If necessary, disconnect any cables connected to the card. If your card includes a retention mechanism, remove the top of the retention mechanism by pressing the tab and pulling up on the top. Gently pull the securing tab, grasp the card by its top corners, and then ease it out of its connector.

5. Prepare the card for installation.

See the documentation that came with the card for information on configuring the card, making internal connections, or otherwise customizing it for your computer.

⚠ CAUTION: Some network adapters automatically start the computer when they are connected to a network. To guard against electrical shock, be sure to unplug your computer from its electrical outlet before installing any cards.

6. If you are installing the card into the x16 card connector, position the card so the securing slot is aligned with the securing tab, and gently pull the securing tab.
7. Place the card in the connector and press down firmly. Ensure that the card is fully seated in the slot.

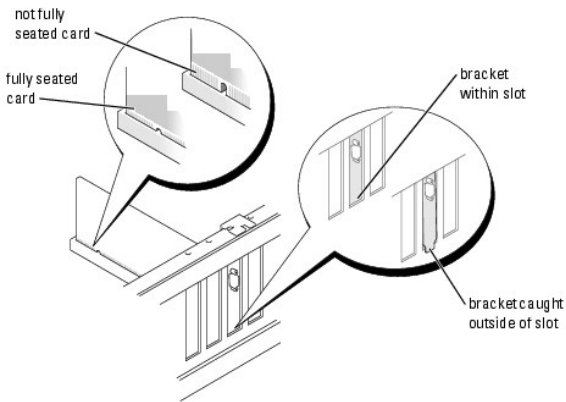

8. If you replaced a card that was already installed in the computer and you removed the top of the retention mechanism, you may reinstall the top.
9. Before you lower the retention arm, ensure that:
 1. The tops of all cards and filler brackets are flush with the alignment bar.
 1. The notch in the top of the card or filler bracket fits around the alignment guide.
10. Press the retention arm into place, securing the card(s) in the computer.

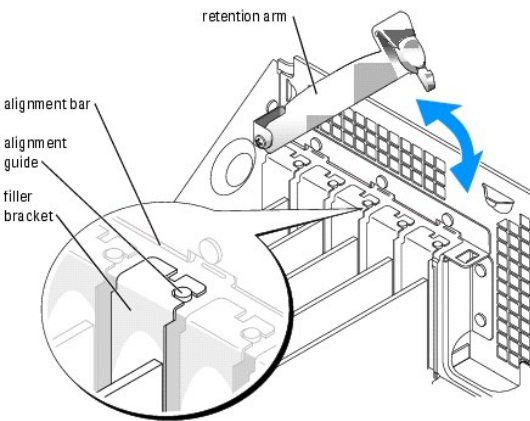

NOTICE: Do not route card cables over or behind the cards. Cables routed over the cards can prevent the computer cover from closing properly or cause damage to the equipment.

If a card fan is not present in your computer and you are installing a graphics card that runs higher than 75 W, contact Dell to find out how to purchase a card fan.

11. If you installed a PCI Express graphics card that runs at 75 W or higher, install the card fan. Contact Dell to find out how to purchase a card fan.
12. Connect any cables that should be attached to the card.
See the documentation that came with the card for information about the card's cable connections.

NOTICE: To connect a network cable, first plug the cable into the network device and then plug it into the computer.

13. [Close the computer cover](#), reconnect the computer and devices to electrical outlets, and then turn them on.
14. If you installed a sound card:
 - a. [Enter system setup](#), select **Audio Controller**, and then change the setting to **Off**.
 - b. Connect external audio devices to the sound card's connectors. Do not connect external audio devices to the microphone, speaker/headphone, or line-in connectors on the back panel.
15. If you installed an add-in network adapter and want to disable the integrated network adapter:
 - a. [Enter system setup](#), select **Network Controller**, and then change the setting to **Off**.

- b. Connect the network cable to the add-in network adapter's connectors. Do not connect the network cable to the integrated connector on the back panel.
16. Install any drivers required for the card as described in the card documentation.

Removing a PCI Express Card

1. Follow the procedures in "[Before You Begin](#)."
2. Press the lever on the card retention arm and raise the retention arm.
3. If necessary, disconnect any cables connected to the card.
4. If your card includes a retention mechanism, remove the top of the retention mechanism by pressing the tab and pulling up on the top.
5. Gently pull back the securing tab, grasp the card by its top corners, and then ease it out of its connector.
6. If you are removing the card permanently, install a filler bracket in the empty card-slot opening.

If you need a filler bracket, contact Dell.

 **NOTE:** Installing filler brackets over empty card-slot openings is necessary to maintain FCC certification of the computer. The brackets also keep dust and dirt out of your computer.

7. Lower the retention arm and press it into place, securing the card(s) in the computer.

 **NOTICE:** To connect a network cable, first plug the cable into the network device and then plug it into the computer.

8. [Close the computer cover](#), reconnect the computer and devices to electrical outlets, and then turn them on.
 9. Remove the card's driver from the operating system.
 10. If you removed a sound card:
 - a. [Enter system setup](#), select **Audio Controller**, and then change the setting to **On**.
 - b. Connect external audio devices to the audio connectors on the back panel of the computer.
 11. If you removed an add-in network connector:
 - a. [Enter system setup](#), select **Network Controller**, and then change the setting to **On**.
 - b. Connect the network cable to the integrated connector on the back panel of the computer.
 12. Install any drivers required for the card as described in the card documentation.
-

Drives

Your computer supports a combination of these devices:

- 1 Up to two hard drives
- 1 One optional floppy drive
- 1 Up to two CD or DVD drives

General Installation Guidelines

Connect serial ATA hard drives and serial CD/DVD drives to the system board connectors labeled SATA-0, SATA-1, SATA-2, or SATA-3. Connect IDE CD/DVD drives to the connector labeled PRI IDE.

When you connect two IDE devices to a single IDE interface cable and configure them for the cable select setting, the device attached to the last connector on the interface cable is the primary or the boot device (drive 0), and the device attached to the middle connector on the interface cable is the secondary device (drive 1). See the drive documentation in your upgrade kit for information on configuring devices for the cable select setting.

Connecting Drive Cables

When you install a drive, you connect two cables—a DC power cable and a data cable—to the back of the drive and to the system board. Some drives may also have an audio connector; one end of the audio cable attaches to the drive connector and the other end attaches to the system board.

Drive Interface Connectors

Serial ATA Connector

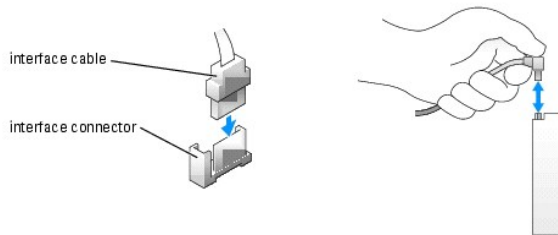

Most interface connectors are keyed for correct insertion; that is, a notch or a missing pin on one connector matches a tab or a filled-in hole on the other connector.

When you connect an IDE cable, ensure that you align the colored stripe with the pin 1 connector. When you disconnect an IDE cable, grasp the colored pull tab and pull until the connector detaches.

When you connect and disconnect a serial ATA cable, hold the cable by the connector at each end.

NOTE: The system board serial ATA connector may have an attached cover or shroud.

Power Cable Connector

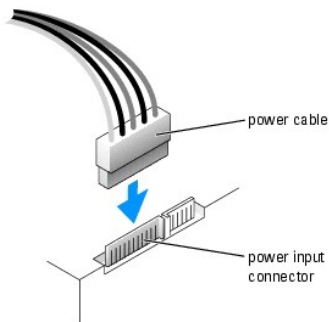

Hard Drive

CAUTION: Before you begin any of the procedures in this section, follow the safety instructions located in the *Product Information Guide*.

CAUTION: To guard against electrical shock, always unplug your computer from the electrical outlet before opening the cover.

NOTICE: To avoid damage to the drive, do not set it on a hard surface. Instead, set the drive on a surface, such as a foam pad, that will sufficiently cushion it.

1. If you are replacing a hard drive that contains data you want to keep, back up your files before you begin to remove the hard drive.
2. Follow the procedures in "[Before You Begin](#)."

Removing a Hard Drive

1. Disconnect the power and data cable from the drive and from the system board.

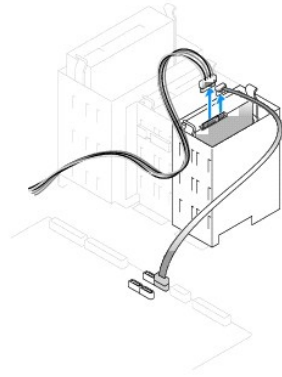

2. Press in on the tabs on each side of the drive and slide the drive up and out.

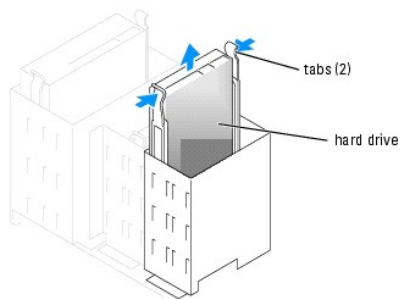

Installing a Hard Drive

1. Unpack the replacement hard drive, and prepare it for installation.
2. Check the documentation for the drive to verify that it is configured for your computer.
3. If your replacement hard drive does not have the bracket rails attached, remove the rails from the old drive by removing the two screws that secure each rail to the drive. Attach the bracket rails to the new drive by aligning the screw holes on the drive with the screw holes on the bracket rails and then inserting and tightening all four screws (two screws on each rail).

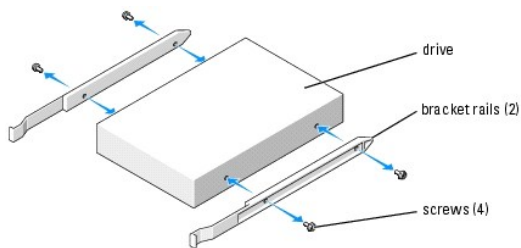

4. Install the hard drive into the computer by gently sliding the drive into place until you hear it securely click.
5. Connect the power and data cable to the drive and to the [system board](#).

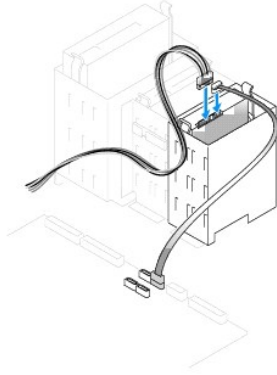

6. Check all connectors to be certain that they are properly cabled and firmly seated.

7. [Close the computer cover.](#)

➡ **NOTICE:** To connect a network cable, first plug the cable into the network device and then plug it into the computer.

8. Connect your computer and devices to electrical outlets, and turn them on.

See the documentation that came with the drive for instructions on installing any software required for drive operation.

9. If the drive you just installed is the primary drive, insert a bootable floppy disk into drive A.

10. Turn on the computer.

11. [Enter system setup](#), and update the appropriate **Drive** option.

12. Exit system setup, and restart the computer.

13. Partition and logically format your drive before you proceed to the next step.

See the documentation for your operating system for instructions.

14. Test the hard drive by running the Dell Diagnostics.

15. If the drive you just installed is the primary drive, install your operating system on the hard drive.

Adding a Second Hard Drive

⚠ **CAUTION:** Before you begin any of the procedures in this section, follow the safety instructions located in the *Product Information Guide*.

⚠ **CAUTION:** To guard against electrical shock, always unplug your computer from the electrical outlet before opening the cover.

➡ **NOTICE:** To avoid damage to the drive, do not set it on a hard surface. Instead, set the drive on a surface, such as a foam pad, that will sufficiently cushion it.

1. Check the documentation for the drive to verify that it is configured for your computer.

2. Follow the procedures in "[Before You Begin](#)."

3. Remove the two plastic rails from the inside of the hard-drive bay by gently pulling the rails up and out of the bay.

4. Attach the rails to the hard drive using the two screws attached to the rails.

Ensure that the rail tabs are positioned at the back of the hard drive.

➡ **NOTICE:** Do not install any drive into the lower hard-drive bay until you have removed the green drive rails from the inside of the hard-drive bay.

5. Remove the first hard drive from the upper bay and install it in the lower bay:

- a. Disconnect the power and the data cable from the back of the first hard drive.
 - b. Press in the two rail tabs and pull the first hard drive out of the upper bay.
 - c. Gently slide the first hard drive into the lower bay until you hear a click.
 - d. Reconnect the power and data cable to the back of the first hard drive.
6. Gently slide the new hard drive into the upper bay until you hear a click.

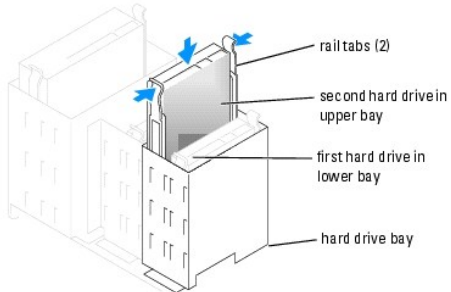

7. Connect a power cable to the drive.
 8. Connect the data cable to the drive and to the [system board](#).
 9. Close the computer cover.
- ➔ **NOTICE:** To connect a network cable, first plug the cable into the network device and then plug it into the computer.
10. Connect your computer and devices to their electrical outlets, and turn them on.
- See the documentation that came with the drive for instructions on installing any software required for drive operation.

Front-Panel Inserts

If you are installing a new floppy or CD/DVD drive instead of replacing a drive, remove the front-panel inserts.

1. Open the cover to a 90-degree angle.
2. Locate the insert that is in front of the drive bay that you want to use.
3. From inside the computer, press in the release tab of the insert.

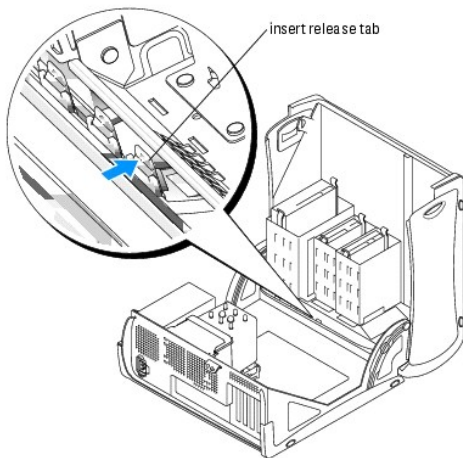

4. From the outside of the computer, pull the insert away from the computer's front panel.
5. Remove the insert from the insert frame by pressing on the four tabs.

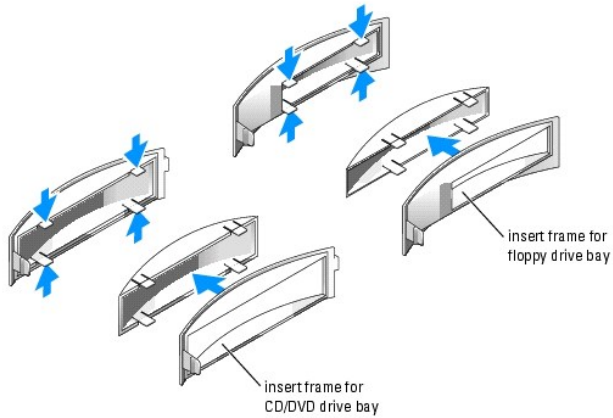

6. Reattach the empty insert frame over the front of the drive bay.

The insert frame fits only one way.

- a. Face the front of the computer and slip the left side of the insert in to the left side of the drive bay opening.
- b. Slightly press the right-side insert release tab and gently push in the insert.

If you are adding a floppy drive and you purchased the drive from Dell, you received a front panel insert in your floppy drive kit. Attach this insert over the front of the drive bay.

front-panel floppy drive insert
included in the floppy drive kit

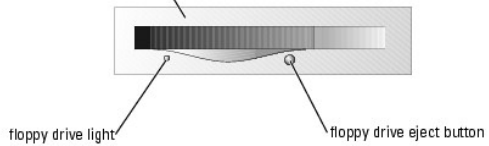

If you are adding a floppy drive that was not purchased from Dell, reattach the empty insert frame over the front of the drive bay.

Floppy Drive

⚠ CAUTION: Before you begin any of the procedures in this section, follow the safety instructions located in the *Product Information Guide*.

⚠ CAUTION: To guard against electrical shock, always unplug your computer from the electrical outlet before opening the cover.

Follow the procedures in "[Before You Begin](#)."

🔧 NOTE: If you are adding a floppy drive, see "[Installing a Floppy Drive](#)."

Removing a Floppy Drive

1. Disconnect the power and data cables from the back of the floppy drive.
2. Disconnect the other end of the data cable from the system board.

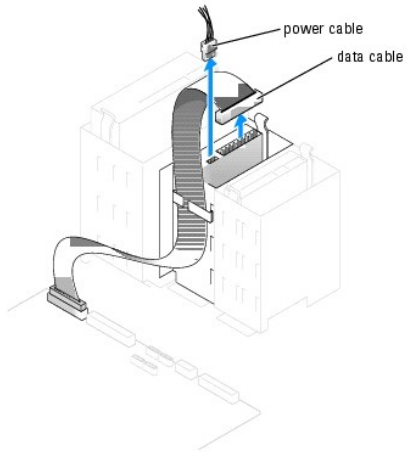

3. Press inward on the two tabs on the sides of the drive, slide the drive upward, and then remove it from the floppy-drive bay.

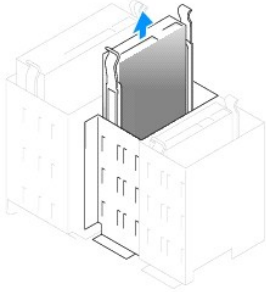

Installing a Floppy Drive

1. If you are replacing a drive and the new drive does not have the bracket rails attached, remove the rails from the old drive by removing the two screws that secure each rail to the drive. Attach the bracket to the new drive by aligning the screw holes on the drive with the screw holes on the bracket rails and then inserting and tightening all four screws (two screws on each rail).

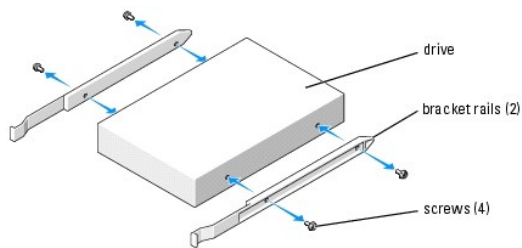

2. Gently slide the drive into place until the tabs securely click into position.
3. Attach the power and data cables to the floppy drive.
4. Connect the other end of the data cable to the connector labeled FLOPPY on the [system board](#).
5. If you are installing a new floppy drive rather than replacing a drive, remove the [front-panel inserts](#).
6. Check all cable connections, and fold cables out of the way to provide airflow for the fan and cooling vents.
7. [Close the computer cover](#).

🔁 **NOTICE:** To connect a network cable, first plug the cable in to the network device and then plug it in to the computer.

8. Connect your computer and devices to their electrical outlets, and turn them on.

See the documentation that came with the drive for instructions on installing any software required for drive operation.

9. [Enter system setup](#) and select the appropriate **Diskette Drive** option.

10. Verify that your computer works correctly by running the Dell Diagnostics.

CD/DVD Drive

⚠️ **CAUTION:** Before you begin any of the procedures in this section, follow the safety instructions located in the *Product Information Guide*.

⚠️ **CAUTION:** To guard against electrical shock, always unplug your computer from the electrical outlet before opening the cover.

Removing a CD/DVD Drive

1. Follow the procedures in "[Before You Begin](#)."

2. Disconnect the power and data cables from the back of the drive.

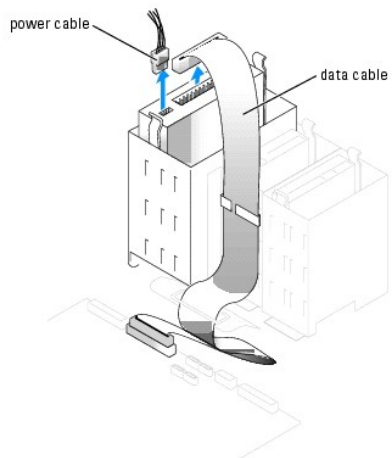

3. Press inward on the two tabs on the sides of the drive, and then slide the drive upward and remove it from the drive bay.

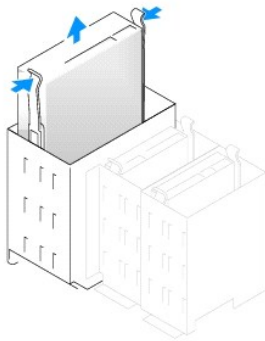

Installing a CD/DVD Drive

1. If you are installing a new drive, unpack the drive and prepare it for installation.

Check the documentation that accompanied the drive to verify that the drive is configured for your computer. If you are installing an IDE drive, configure the drive for the cable select setting.

2. Connect the new drive to the set of rails that are attached to the inside of the cover. If a set of rails is not attached inside the cover, contact Dell.
3. If you are installing a replacement drive and the new drive does not have the bracket rails attached, remove the rails from the old drive by removing the two screws that secure each rail to the drive. Attach the bracket to the new drive by aligning the screw holes on the drive with the screw holes on the bracket rails and then inserting and tightening all four screws (two screws on each rail).

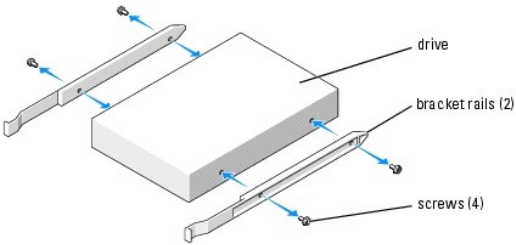

4. Gently slide the drive into place until the tabs securely click into position.
5. Connect the power and data cables to the drive.

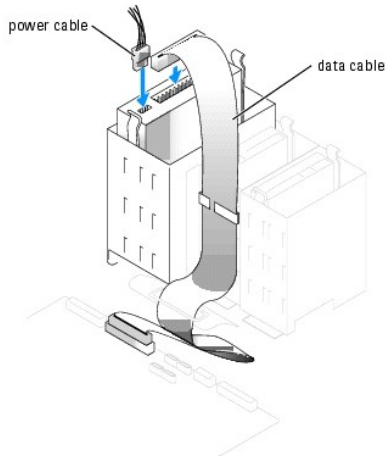

6. If you are installing a new CD/DVD drive rather than replacing a drive, remove the [front-panel inserts](#).
7. Check all cable connections, and fold cables out of the way to provide airflow for the fan and cooling vents.
8. [Close the computer cover](#).

➡ **NOTICE:** To connect a network cable, first plug the cable in to the network device and then plug it in to the computer.

9. Connect your computer and devices to their electrical outlets, and turn them on.

See the documentation that came with the drive for instructions on installing any software required for drive operation.

10. [Enter system setup](#) and select the appropriate **Drive** option.
11. Verify that your computer works correctly by running the Dell Diagnostics.

Airflow Shroud

Removing the Airflow Shroud

⚠ CAUTION: Before you begin any of the procedures in this section, follow the safety instructions in the *Product Information Guide*.

1. Follow the procedures in "[Before You Begin](#)."
2. Disconnect the cooling fan power cable from the fan connector on the system board.
3. Disconnect the power cable from the power connector on the system board.
4. Lift up the airflow shroud.

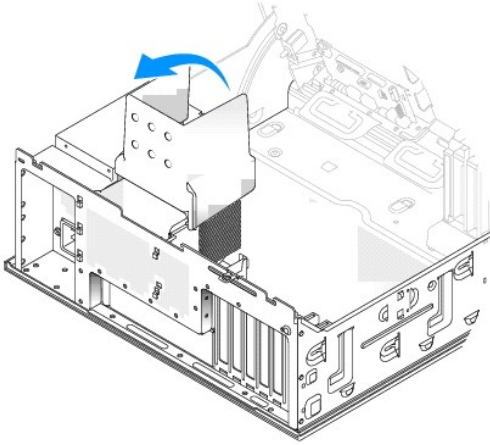

Processor

⚠ CAUTION: Before you begin any of the procedures in this section, follow the safety instructions in the *Product Information Guide*.

🔄 NOTICE:

1. Follow the procedures in "[Before You Begin](#)."

⚠ CAUTION: The heat sink can get very hot during normal operation. Be sure that the heat sink has had sufficient time to cool before you touch it.

2. Remove the heat sink:
 - a. Remove the retention module clips. Press the tabs toward the center of the clip and lift up.

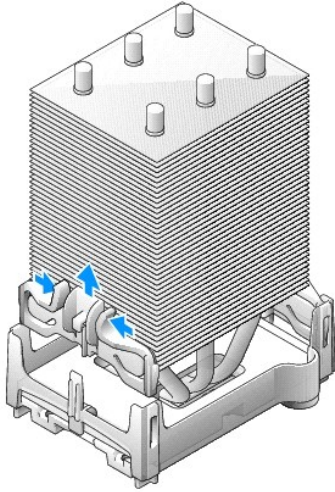

- b. On the retention base locate the tab opposite the power supply. Press on the retention base tab until the heat sink pops up slightly.
- c. Press out on the second retention tab while lifting the heat sink up and out of the retention base.

➡ **NOTICE:** Lay the heat sink down on its side. Do not touch or remove the thermal grease on the bottom of the heat sink.

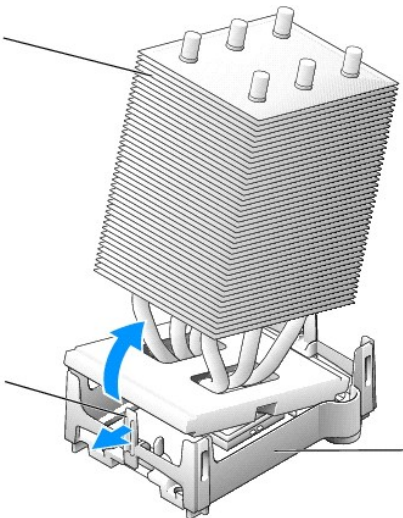

➡ **NOTICE:** If you are installing a processor upgrade kit from Dell, discard the original heat sink. If you are *not* installing a processor upgrade kit from Dell, reuse the original heat sink and blower when you install your new processor.

3. Push down and out on the socket release lever.
4. Open the processor cover.

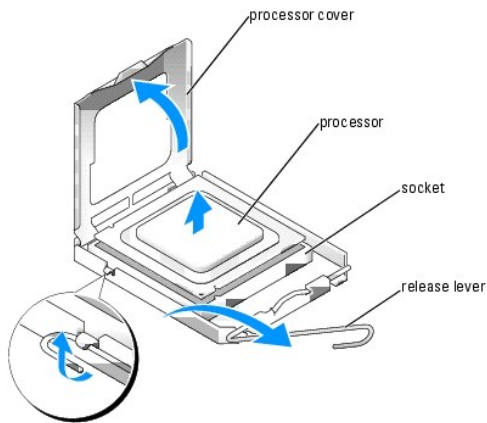

5. To remove the processor from the socket, lift the processor vertically in one motion.

Leave the release lever extended in the release position so that the socket is ready for the new processor.

Installing the Processor

- ➔ **NOTICE:** Ground yourself by touching an unpainted metal surface on the back of the computer.

1. Unpack the new processor.

- ➔ **NOTICE:** You must position the processor correctly in the socket to avoid permanent damage to the processor and the computer when you turn on the computer.

2. If the release lever on the socket is not fully extended, move it to that position.

3. Align the pin-1 corners of the processor and socket.

- ➔ **NOTICE:** To avoid damage, ensure that the processor aligns properly with the socket, and do not use excessive force when you install the processor.

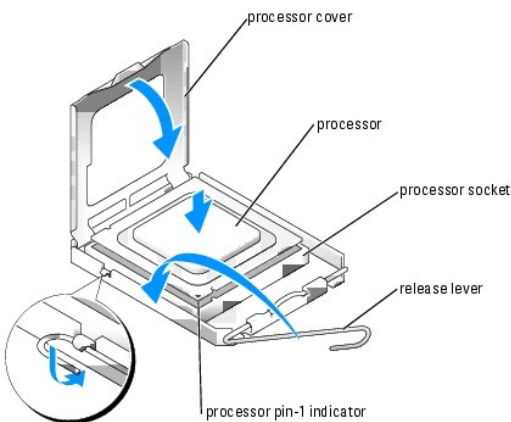

- ➔ **NOTICE:** Be careful not to touch or bend the pins on the system board.

4. Set the processor lightly in the socket and ensure that the processor is level in the socket. When the processor is positioned correctly, press it with minimal pressure to seat it.

5. When the processor is fully seated in the socket, close the processor cover.

Ensure that the tab on the processor cover is positioned underneath the center cover latch on the socket.

- Pivot the socket release lever back toward the socket and snap it into place to secure the processor.

➡ **NOTICE:** If you are *not* installing a processor upgrade kit from Dell, reuse the original heat sink assembly when you replace the processor.

If you installed a processor replacement kit from Dell, return the original heat sink assembly and processor to Dell in the same package in which your replacement kit was sent.

- Install the heat sink:
 - Slide one end of the heat sink under the retention tab.
 - Pull out the other retention tab and lower the heat sink until it fits securely in the base.

➡ **NOTICE:** Ensure the heat sink is correctly seated and secure.

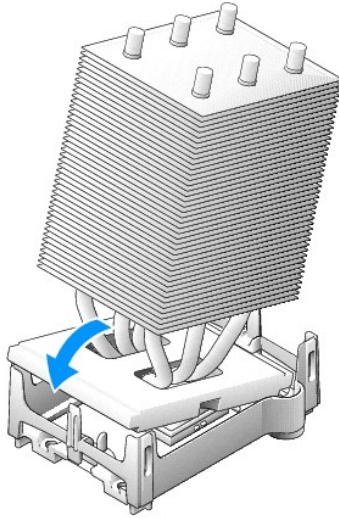

- Reinstall the retention module clips.
- Lower the airflow shroud over the heat sink.
- Reconnect the cooling fan power cable to the fan connector on the system board.
- Reconnect the power cable to the power connector on the system board.
- [Close the computer cover.](#)

➡ **NOTICE:** To connect a network cable, first plug the cable into the network wall jack and then plug it into the computer.

- Connect your computer and devices to electrical outlets, and turn them on.

System Board

⚠ **CAUTION:** Before you begin any of the procedures in this section, follow the safety instructions located in the *Product Information Guide*.

⚠ **CAUTION:** To prevent static damage to components inside your computer, discharge static electricity from your body before you touch any of your computer's electronic components. You can do so by touching an unpainted metal surface on the computer chassis.

➡ **NOTICE:** The system board and metal tray are connected and are removed as one piece.

Removing the System Board

- Follow the procedures in "[Before You Begin](#)."

2. [Open the computer cover.](#)
3. Remove any components that restrict access to the system board.
4. Disconnect all cables from the system board.
5. Before you remove the existing system board assembly, visually compare the replacement system board to the existing system board to make sure that you have the correct part.
6. Remove the system board screw.

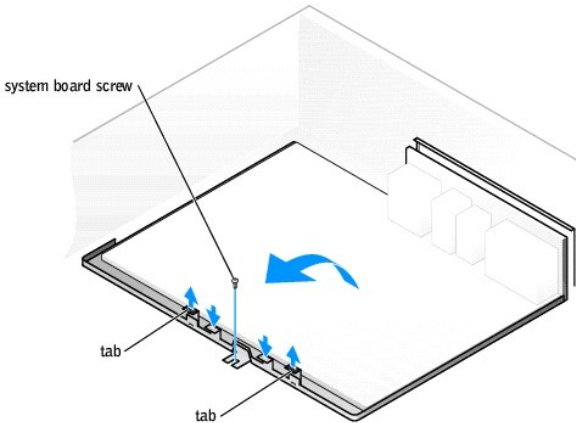

7. Pull up on the two tabs, slide the system board assembly toward the front of the computer, and then lift the assembly up and away.
8. Place the system board assembly that you just removed next to the replacement system board.

Replacing the System Board

1. Transfer components from the existing system board to the replacement system board:
 - a. Remove the [memory modules](#) and install them on the replacement board.
 - b. Install them on the replacement board.

⚠ CAUTION: The processor package and heat-sink assembly can get hot. To avoid burns, ensure that the package and assembly have had sufficient time to cool before you touch them.

- c. Remove the [heat-sink assembly and processor](#) from the existing system board and transfer them to the replacement system board.
2. Configure the settings of the replacement system board.
 3. Set the jumpers on the replacement system board so they are identical to the ones on the existing board.

🔧 NOTE: Some components and connectors on the replacement system board may be in different locations than the corresponding connectors on the existing system board.

4. Orient the replacement board by aligning the notches on the bottom of the board with the tabs on the computer.
5. Slide the system board assembly toward the back of the computer until the assembly clicks into position.
6. Replace any components and cables that you removed from the system board.
7. Reconnect all cables to their connectors at the back of the computer.
8. [Close the computer cover.](#)

👉 NOTICE: To connect a network cable, first plug the cable into the network wall jack and then plug it into the computer.

9. Connect your computer and devices to electrical outlets, and turn them on.

Power Supply

Removing the Power Supply

NOTICE: To prevent static damage to components inside your computer, discharge static electricity from your body before you touch any of your computer's electronic components. You can do so by touching an unpainted metal surface on the computer chassis.

CAUTION: Before you begin any of the procedures in this section, follow the safety instructions located in the *Product Information Guide*.

1. Follow the procedures in "[Before You Begin](#)."
2. Disconnect the DC power cables from the system board and the drives.

Note the routing of the DC power cables underneath the tabs in the computer frame as you remove them from the system board and drives. You must route these cables properly when you replace them to prevent their being pinched or crimped.

3. Remove the two screws that attach the power supply to the back of the computer frame.
4. Press the release button located on the floor of the computer frame.

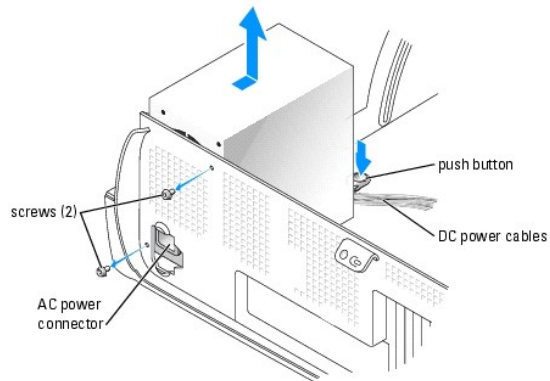

5. Slide the power supply toward the front of the computer approximately 1 inch.
6. Lift the power supply up and out of the computer.

Replacing the Power Supply

CAUTION: Before you begin any of the procedures in this section, follow the safety instructions located in the *Product Information Guide*.

1. Slide the power supply into place.
2. Replace the two screws that secure the power supply to the back of the computer frame.
3. Reconnect the DC power cables.
4. Connect the AC power cable to the connector.
5. Run the cables underneath the clips, and press the clips to close them over the cables.
6. [Close the computer cover](#).

NOTICE: To connect a network cable, first plug the cable into the network wall jack and then plug it into the computer.

7. Connect your computer and devices to electrical outlets, and turn them on.
-

Battery

Replacing the Battery

⚠ CAUTION: Before you begin any of the procedures in this section, follow the safety instructions located in the *Product Information Guide*.

➡ NOTICE: To prevent static damage to components inside your computer, discharge static electricity from your body before you touch any of your computer's electronic components. You can do so by touching an unpainted metal surface on the computer chassis.

A coin-cell battery maintains computer configuration, date, and time information. The battery can last several years.

If you have to repeatedly reset time and date information after turning on the computer, replace the battery.

⚠ CAUTION: A new battery can explode if it is incorrectly installed. Replace the battery only with the same or equivalent type recommended by the manufacturer. Discard used batteries according to the manufacturer's instructions.

To replace the battery:

1. Record all the screens in system setup so that you can restore the correct settings in [step 8](#).
2. Follow the procedures in "[Before You Begin](#)."
3. Locate the battery socket on the [system board](#).
4. Remove the battery by pressing on the tab, which will release the battery from the battery socket.
5. Insert the new battery into the socket with the side labeled "+" facing up, and snap the battery into place.

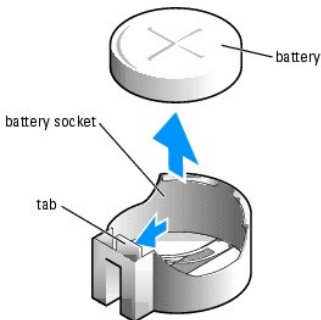

6. Close the computer cover.

➡ NOTICE: To connect a network cable, first plug the cable into the network device and then plug it into the computer.

7. Connect your computer and devices to electrical outlets, and turn them on.
 8. [Enter system setup](#) and restore the settings you recorded in [step 1](#).
 9. Properly dispose of the old battery. See the *Product Information Guide* for battery disposal information.
-

[Back to Contents Page](#)

Specifications

Dell™ Dimension™ 8400 Service Manual

Processor	
Processor type	Intel® Pentium® 4 with HT Technology NOTE: Not all Pentium 4 processors support Hyper-Threading technology.
Level 1 (L1) cache	16 KB
Level 2 (L2 or L3) cache	512 KB, 1 MB, or 2 MB (depending on your computer configuration) pipelined-burst, eight-way set associative, write-back SRAM

Memory	
Type	400- and 533-MHz DDR2 unbuffered SDRAM
Memory connectors	four
Memory capacities	128-, 256-, 512-, or 1-GB non-ECC
Maximum memory	4 GB NOTE: See " Addressing Memory With 4-GB Configurations " to verify the amount of memory available to the operating system.
BIOS address	F0000h

Computer Information	
Chipset	Intel 925X Express or Intel 925XE Express
DMA channels	eight
Interrupt levels	24
BIOS chip (NVRAM)	4-Mb
NIC	Integrated network interface capable of 10/100/1000 communication.
System clock	800- or 1066-MHz data rate (depending on your processor)

Video	
Type	PCI Express

Audio	
Type	ADI 1980 AC'97 Codec NOTE: This audio type is present only on computers with integrated sound capabilities.

Expansion Bus	
Bus type	PCI 2.3 PCI Express x1 and x16
Bus speed	PCI: 33 MHz PCI Express: x1 slot bidirectional speed — 500 MB/s

	x16 slot bidirectional speed — 8 GB/s
PCI	
connector	three
connector size	120 pins
connector data width (maximum)	32 bits
PCI Express	
connector	one x1
connector size	36 pins
connector data width (maximum)	1 PCI Express lane
PCI Express	
connectors	one x16
connector size	164 pins
connector data width (maximum)	16 PCI Express lanes

Drives	
Externally accessible:	
	two 3.5-inch drive bays
	two 5.25-inch drive bays
Available devices	Serial ATA drive, floppy drive, Zip drive, USB memory devices, CD drive, CD-RW drive, DVD drive, DVD-RW drive, and DVD and CD-RW combo drive
Internally accessible:	two bays for 1-inch high hard drives

Connectors	
External connectors:	
Serial	9-pin connector; 16550C-compatible
Parallel	25-hole connector (bidirectional)
Video	15-hole connector
Network adapter	RJ45 connector
PS/2 (keyboard and mouse)	two 6-pin mini-DIN connectors
USB	two front-panel and six back-panel USB 2.0-compliant connectors
Audio	five connectors for line-in, line-out, microphone, surround, and center/Low Frequency Effects (LFE) channel; one front-panel connector for headphones
System board connectors:	
Primary IDE drive	40-pin connector on PCI local bus
Serial ATA	four 7-pin connectors
Floppy drive	34-pin connector
Fan	two 5-pin connectors
PCI 2.3	120-pin connector
PCI Express x1	36-pin connector
PCI Express x16	164-pin connector
Telephony (TAPI)	4-pin connector

Controls and Lights	
Power control	push button
Power light	green light — Blinking green in sleep state; solid green for power-on state. amber light — Blinking amber indicates a problem with an installed device; solid amber indicates an internal power problem (see " Power Lights ").
Hard-drive access light	green
Link integrity light (on integrated network adapter)	green light — A good connection exists between a 10-Mbps network and the computer.

	<p>orange light — A good connection exists between a 100-Mbps network and the computer.</p> <p>yellow light — A good connection exists between a 1 Gb (or 1000-Mbps) network and the computer.</p> <p>off (no light) — The computer is not detecting a physical connection to the network.</p>
Activity light (on integrated network adapter)	yellow blinking light
Diagnostic lights	four lights on the back panel (See " Diagnostic Lights ,")
Standby power light	AUX_PWR on the system board

Power	
DC power supply:	
Wattage	350 W
Heat dissipation	460.7 BTU/hr
Voltage (see the safety instructions located in the <i>Product Information Guide</i> for important voltage setting information)	<p>fixed-voltage power supply — 110 V at 50/60 Hz</p> <p>manual selection and auto-sensing power supplies — 90 to 135 V at 50/60 Hz; 180 to 265 V at 50/60 Hz; 100 V at 50/60 Hz for Japanese computers</p>
Backup battery	3-V CR2032 lithium coin cell

Physical	
Height	42.5 cm (16.7 inches)
Width	18.1 cm (7.1 inches)
Depth	44.7 cm (17.6 inches)
Weight	12.7 kg (28 lb)

Environmental	
Temperature:	
Operating	<p>10° to 35°C (50° to 95°F)</p> <p>NOTE: At 35°C (95°F), the maximum operating altitude is 914 m (3000 ft).</p>
Storage	-40° to 65°C (-40° to 149°F)
Relative humidity	20% to 80% (noncondensing)
Maximum vibration:	
Operating	0.25 G at 3 to 200 Hz at 0.5 octave/min
Storage	0.5 G at 3 to 200 Hz at 1 octave/min
Maximum shock:	
Operating	bottom half-sine pulse with a change in velocity of 20 inches/sec (50.8 cm/sec)
Storage	27-G faired square wave with a velocity change of 200 inches/sec (508 cm/sec)
Altitude:	
Operating	-15.2 to 3048 m (-50 to 10,000 ft)
Storage	-15.2 to 10,668 m (-50 to 35,000 ft)

[Back to Contents Page](#)

System Setup

Dell™ Dimension™ 8400 Service Manual

- [Overview](#)
- [Entering System Setup](#)
- [System Setup Screens](#)
- [System Setup Options](#)
- [Boot Sequence](#)
- [Clearing Forgotten Passwords](#)
- [Clearing CMOS Settings](#)

Overview

Use system setup as follows:

- 1 To change the system configuration information after you add, change, or remove any hardware in your computer
- 1 To set or change a user-selectable option such as the user password
- 1 To read the current amount of memory or set the type of hard drive installed

Before you use system setup, it is recommended that you write down the system setup screen information for future reference.

 **NOTICE:** Unless you are an expert computer user, do not change the settings for this program. Certain changes can make your computer work incorrectly.

Entering System Setup

1. Turn on (or restart) your computer.
2. When the blue DELL™ logo appears, press <F2> immediately.
3. If you wait too long and the operating system logo appears, continue to wait until you see the Microsoft® Windows® desktop. Turn off your computer, and try again.

System Setup Screens

The system setup screen displays current or changeable configuration information for your computer. Information on the screen is divided into three areas: the options list, active options field, and key functions.

<p>Options List — This field appears on the left side of the system setup window. The field is a scrollable list containing features that define the configuration of your computer, including installed hardware, power conservation, and security features.</p> <p>Scroll up and down the list with the up- and down-arrow keys. As an option is highlighted, the Option Field displays more information about that option and the option's current and available settings.</p>	<p>Option Field — This field contains information about each option. In this field you can view your current settings and make changes to your settings.</p> <p>Use the right and left arrow keys to highlight an option. Press <Enter> to make that selection active.</p> <p>Key Functions — This field appears below the Option Field and lists keys and their functions within the active system setup field.</p>
---	---

System Setup Options

 **NOTE:** Depending on your computer and installed devices, the items listed in this section may not appear, or may not appear exactly as listed.

System	
CPU Info	Identifies whether the computer's processor supports Hyper-Threading and lists the processor bus speed, processor ID, clock speed, and L2 cache.
Memory Info	Indicates amount of installed memory, memory speed, channel mode (dual or single), and type of memory installed.
Date/Time	Displays current date and time settings.
Boot Sequence	The computer attempts to boot from the sequence of devices specified in this list.

	NOTE: If you insert a boot device and restart the computer, this option appears in the system setup menu. To boot from a USB memory device, select the USB device and move it so it becomes the first device in the list.
Drives	
Diskette Drive	Identifies and defines the floppy drive attached to the FLOPPY connector on the system board as Off , USB , Internal , or Read Only .
Drives 0 through 5	Identifies the drives attached to the SATA or PRI IDE connectors on the system board, and lists the capacity for hard drives.
Drive Controller	Identifies and defines the SATA controller settings for RAID. You can set the SATA controller to RAID Autodetect/AHCI , RAID Autodetect/ATA , or RAID On .
Onboard Devices	
NIC Controller	You can set the NIC to On (default), Off , or On w/ PXE . When the On w/ PXE setting is active (available only for the future boot process), the computer prompts the user to press <Ctrl><Alt>. Pressing this key combination causes a menu to display that allows you to select a method for booting from a network server. If a boot routine is not available from the network server, the computer attempts to boot from the next device in the boot sequence list.
Audio Controller	Enables or disables the onboard audio controller.
USB	Set to On (default) so that USB devices will be detected and supported in the operating system.
Mouse Port	Enables or disables the onboard PS/2-compatible mouse controller.
LPT Port Mode	Identifies and defines the parallel port settings. You can set the parallel port to Off , AT , PS/2 , EPP , or ECP .
LPT Port Address	Identifies the address for the parallel port.
LPT Port DMA	Identifies and defines the parallel port DMA settings. You can set the parallel port DMA to Off , DMA1 , or DMA3 .
Serial Port #1	Identifies and defines the serial port settings. Auto , the default setting, automatically configures a connector to a particular designation (COM1 or COM3).
Video	
Primary Video	This setting specifies which video controller is primary when two video controllers are present on the computer.
Performance	
HyperThreading	If your computer's processor supports Hyper-Threading, this option appears in the Options List.
Performance	<ul style="list-style-type: none"> 1 Bypass — Your computer does not test or change the current acoustics mode setting. 1 Quiet (default) — The hard drive operates at its most quiet setting. 1 Suggested — The hard drive operates at the level suggested by the drive manufacturer. 1 Performance — The hard drive operates at its maximum speed. <p>NOTE: Switching to performance mode may cause the drive to be noisier, but its performance is not affected.</p> <p>NOTE: Changing the acoustics setting does not alter your hard drive image.</p>
Security	This section displays available system security options.
Admin Password	This option provides restricted access to the computer's system setup program in the same way that access to the system can be restricted with the System Password option.
System Password	Displays the current status of the system's password security feature and allows a new system password to be assigned and verified.
Password Status	This option locks the system password field with the setup password. When the field is locked, you can no longer disable password security by pressing <Ctrl><Enter> when the computer starts.
Power Management	
AC Recovery	Determines what happens when AC power is restored to the computer.
Auto Power On	<p>Sets the computer to automatically turn on. Choices are every day or every Monday through Friday.</p> <p>The default setting is Off.</p> <p>This feature does not work if you turn off your computer using a power strip or surge protector.</p>
Auto Power Time	<p>Sets time to automatically turn on the computer.</p> <p>Time is kept in a 24-hour format (<i>hours:minutes</i>). Change the start-up time by pressing the right- or left-arrow key to increase or decrease the numbers, or type numbers in both the date and time fields.</p> <p>This feature does not work if you turn off your computer using a power strip or surge protector.</p>
Low Power Mode	When Low Power Mode is selected, remote wakeup events no longer power up from Hibernate or Off .
Remote Wake Up	<p>This option allows the computer to power up when a NIC or Remote Wakeup-capable modem receives a wake up signal.</p> <p>On is the default setting. On w/ Boot to NIC allows the computer to attempt to boot from a network prior to using the boot sequence.</p> <p>NOTE: Normally, the system can be powered up remotely from suspend mode, hibernate mode, or when powered off. When Low Power Mode (in the Power Management menu) is enabled, the computer can only be powered up remotely from Suspend.</p>
Suspend Mode	The options are S1 , a suspend state where the computer is running in a low-power mode, and S3 , a standby state where the power is reduced or turned off for most components, however, system memory remains active.
Maintenance	
CMOS Defaults	This setting restores the computer's factory-installed default settings.

Event Log	Displays the system event log.
BIOS Update	After downloading a new version of the BIOS, use this option to identify and define the location of the BIOS update file. The options are Diskette or Disk .
POST Behavior	
Fastboot	When set to On (default), your computer starts more quickly because it skips certain configurations and tests.
Numlock Key	This option involves the rightmost bank of keys on your keyboard. When set to On (default), this option activates the numeric and mathematical features shown at the top of each key. When set to Off , this option activates the cursor-control functions labeled on the bottom of each key.
OS Install	This setting turns the OS Install Mode either On or Off (default).
POST Hotkeys	This option allows you to specify the function keys to display on the screen when the computer starts.
Keyboard Errors	This option disables or enables keyboard error reporting when the computer starts.

Boot Sequence

This feature allows you to change the boot sequence for devices.

Option Settings

1. **Diskette Drive** — The computer attempts to boot from the floppy drive. If the floppy disk in the drive is not bootable, if no floppy disk is in the drive, or if there is no floppy drive installed in the computer, the computer generates an error message.
1. **Hard Drive** — The computer attempts to boot from the primary hard drive. If no operating system is on the drive, the computer generates an error message.
1. **CD Drive** — The computer attempts to boot from the CD drive. If no CD is in the drive, or if the CD has no operating system, the computer generates an error message.
1. **USB Flash Device** — Insert the memory device into a USB port and restart the computer. When **F12 = Boot Menu** appears in the upper-right corner of the screen, press <F12>. The BIOS detects the device and adds the USB flash option to the boot menu.

 **NOTE:** To boot to a USB device, the device must be bootable. To make sure that your device is bootable, check the device documentation.

Changing Boot Sequence for the Current Boot

You can use this feature, for example, to tell the computer to restart your computer to a USB device such as a floppy drive, memory key, or CD-RW drive.

 **NOTE:** If you are booting to a USB floppy drive, you must first set the floppy drive to OFF in system setup.

1. If you are booting to a USB device, connect the USB device to a USB connector.
2. Turn on (or restart) your computer.
3. When **F2 = Setup**, **F12 = Boot Menu** appears in the upper-right corner of the screen, press <F12>.

If you wait too long and the operating system logo appears, continue to wait until you see the Microsoft Windows desktop. Then [shut down your computer](#) and try again.

The **Boot Device Menu** appears, listing all available boot devices. Each device has a number next to it.

4. At the bottom of the menu, enter the number of the device that is to be used for the current boot only.
For example, if you are booting to a USB memory key, highlight **USB Flash Device** and press <Enter>.

 **NOTE:** To boot to a USB device, the device must be bootable. To make sure your device is bootable, check the device documentation.

Changing Boot Sequence for Future Boots

1. [Enter system setup](#).
2. Use the arrow keys to highlight the **Boot Sequence** menu option and press <Enter> to access the menu.

 **NOTE:** Write down your current boot sequence in case you want to restore it.

3. Press the up- and down-arrow keys to move through the list of devices.

4. Press the spacebar to enable or disable a device (enabled devices have a checkmark).
 5. Press plus (+) or minus (-) to move a selected device up or down the list.
-

Clearing Forgotten Passwords

⚠ CAUTION: Before you begin any of the procedures in this section, follow the safety instructions located in the *Product Information Guide*.

1. Follow the procedures in "[Before You Begin](#)."

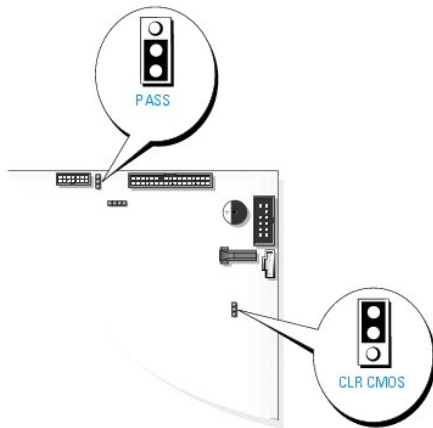

2. Locate the 3-pin password jumper (PASS) on the [system board](#), and attach the jumper plug to pins 2 and 3 to clear the password.

🔍 NOTE: When you receive your computer, the jumper plug is attached to pins 1 and 2.

3. [Close the computer cover](#).
4. Connect your computer and monitor to electrical outlets, and turn them on.
5. After the Microsoft® Windows® desktop appears on your computer, [shut down the computer](#).
6. Turn off the monitor and disconnect it from the electrical outlet.
7. Disconnect the computer power cable from the electrical outlet, and press the power button to ground the system board.
8. [Open the computer cover](#).
9. Locate the 3-pin password jumper (PASS) on the [system board](#) and attach the jumper to pins 1 and 2 to re-enable the password feature.
10. [Close the computer cover](#).

🔄 NOTICE: To connect a network cable, first plug the cable into the network device and then plug it into the computer.

11. Connect your computer and devices to electrical outlets, and turn them on.
-

Clearing CMOS Settings

⚠ CAUTION: Before you begin any of the procedures in this section, follow the safety instructions located in the *Product Information Guide*.

1. Follow the procedures in "[Before You Begin](#)."
2. Reset the current CMOS settings:

- a. Locate the 3-pin CMOS jumper (CLR CMOS) [on the system board](#).
- b. Remove the jumper plug from pins 2 and 3.
- c. Place the jumper plug on pins 1 and 2 and wait approximately 5 seconds.
- d. Replace the jumper plug on pins 2 and 3.

3. [Close the computer cover](#).

 **NOTICE:** To connect a network cable, first plug the cable into the network wall jack and then plug it into the computer.

4. Connect your computer and devices to electrical outlets, and turn them on.

[Back to Contents Page](#)

[Back to Contents Page](#)

Technical Overview

Dell™ Dimension™ 8400 Service Manual

- [Inside Your Computer](#)
 - [System Board Components](#)
 - [Power Supply DC Connector Pin Assignments](#)
-

Inside Your Computer

⚠ CAUTION: Before you begin any of the procedures in this section, follow the safety instructions located in the *Product Information Guide*.

Follow the procedures in "[Before You Begin](#)."

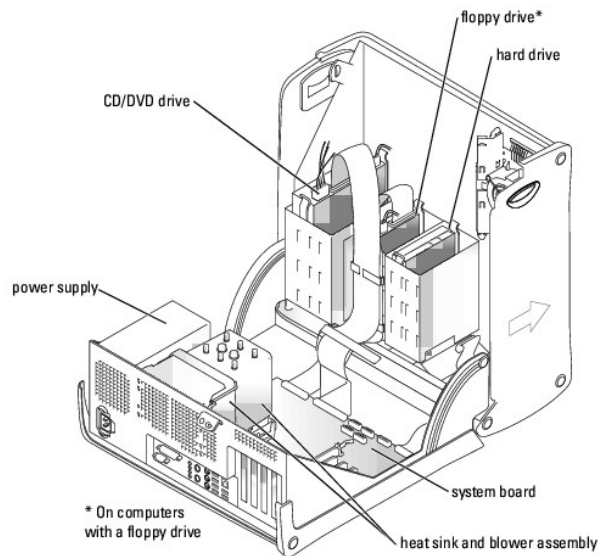

System Board Components

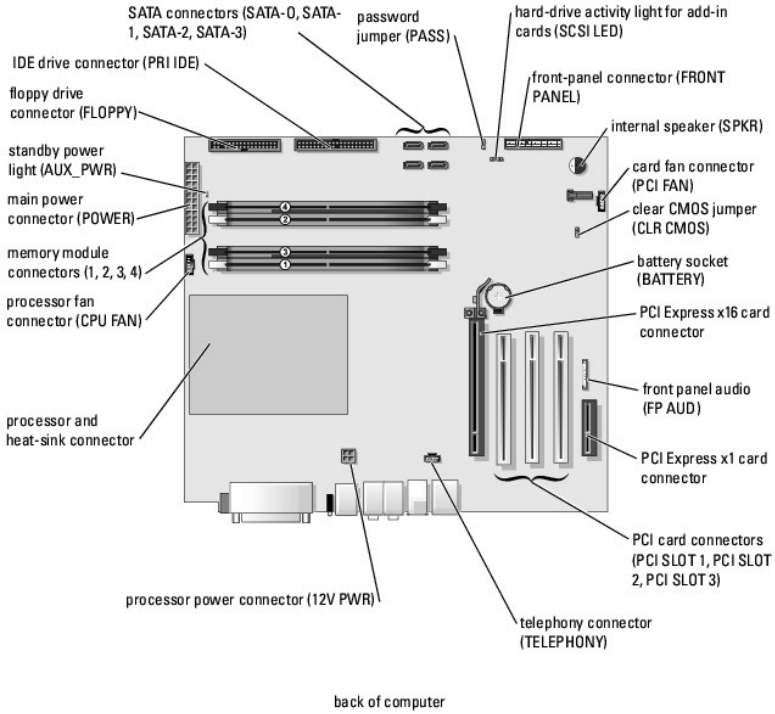

Power Supply DC Connector Pin Assignments

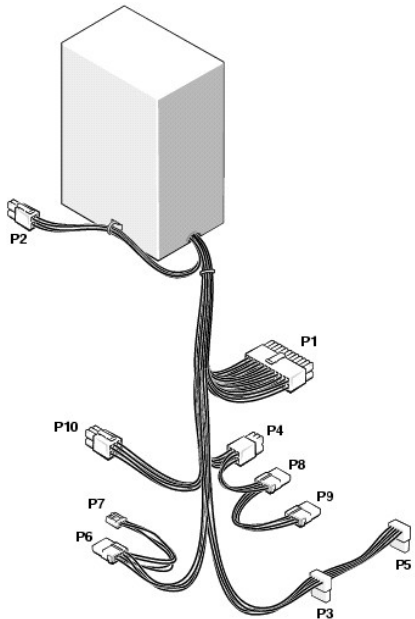

DC Power Connector P1

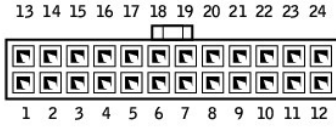

Pin Number	Signal name	Color	Wire Gauge
1	+3.3 VDC	Orange	16-AWG
2	+3.3 VDC	Orange	16-AWG
3	COM	Black	18-AWG
4	+5 VDC	Red	18-AWG
5	COM	Black	18-AWG
6	+5 BDC	Red	18-AWG
7	COM	Black	18-AWG
8	POK	Gray	18-AWG
9	+5 VFP	Purple	18-AWG
10	+12 VB DC	White	18-AWG
11	+12VB DC	White	18-AWG
12	+3.3 VDC	Orange	16-AWG
13	+3.3 VDC	Orange	16-AWG
14	-12 VDC	Blue	18-AWG
15	COM	Black	18-AWG
16	PS-ON	Green	18-AWG
17	COM	Black	18-AWG
18	COM	Black	18-AWG
19	COM	Black	18-AWG
20	N/C	N/C	18-AWG
21	+5 VDC	Red	18-AWG
22	+5 VDC	Red	18-AWG
23	+5 VDC	Red	18-AWG
24	COM	Black	18-AWG

DC Power Connector P2



Pin Number	Signal Name	18-AWG Wire
1	COM	Black
2	COM	Black
3	+12 VA DC	Yellow
4	+12 VA DC	Yellow

DC Power Connectors, P3 and P5

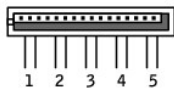

Pin Number	Signal Name	18-AWG Wire
1	+3.3 VDC	Orange

2	COM	Black
3	+5 VDC	Red
4	COM	Black
5	+12 VB DC	White

DC Power Connector P4

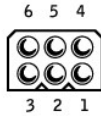

Pin Number	Signal Name	18-AWG Wire
1	N/C	N/C
2	COM	Black
3	COM	Black
4	+3.3 VDC	Orange
5	+5 VDC	Red
6	+12B VDC	White

DC Power Connector P6

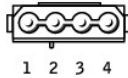

Pin Number	Signal Name	18-AWG Wire
1	+12 VB DC	Yellow
2	COM	Black
3	COM	Black
4	+5V DC	Red

DC Power Connector P7

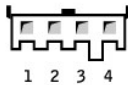

Pin Number	Signal Name	18-AWG Wire
1	+5 VDC	Red
2	COM	Black
3	COM	Black
4	+12 A VDC	Yellow

DC Power Connectors, P8 and P9

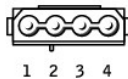

Pin Number	Signal Name	18-AWG Wire
------------	-------------	-------------

1	+12 VB DC	White
2	COM	Black
3	COM	Black
4	+5V DC	Red

DC Power Connector P10

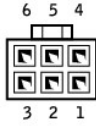

Pin Number	Signal Name	18-AWG Wire
1	+12 B VDC	White
2	+12 B VDC	White
3	+12 B VDC	White
4	COM	Black
5	COM	Black
6	COM	Black



 **NOTE:** The P10 connector is intended for use with [PCI Express graphics cards](#) that have power requirements exceeding 75 watts.

[Back to Contents Page](#)

[Back to Contents Page](#)

Dell™ Dimension™ 8400 Systems Service Manual

Notes, Notices, and Cautions

-  **NOTE:** A NOTE indicates important information that helps you make better use of your computer.
 -  **NOTICE:** A NOTICE indicates either potential damage to hardware or loss of data and tells you how to avoid the problem.
 -  **CAUTION:** A CAUTION indicates a potential for property damage, personal injury, or death.
-

Abbreviations and Acronyms

For a complete list of abbreviations and acronyms, see the *Dell Dimension Owner's Manual*.

If you purchased a Dell™ n Series computer, any references in this document to Microsoft® Windows® operating systems are not applicable.

Information in this document is subject to change without notice.
© 2004 Dell Inc. All rights reserved.

Reproduction in any manner whatsoever without the written permission of Dell Inc. is strictly forbidden.

Trademarks used in this text: *Dell*, the *DELL* logo, *Inspiron*, *Dell Precision*, *Dimension*, *OptiPlex*, *Latitude*, *PowerEdge*, *PowerVault*, *PowerApp*, and *Dell OpenManage* are trademarks of Dell Inc.; *Intel* and *Pentium* are registered trademarks of Intel Corporation; *Microsoft*, *Windows*, and *MS-DOS* are registered trademarks of Microsoft Corporation.

Other trademarks and trade names may be used in this document to refer to either the entities claiming the marks and names or their products. Dell Inc. disclaims any proprietary interest in trademarks and trade names other than its own.

Model DHM

October 2004 Rev. A00

[Back to Contents Page](#)